

**READ COMPLETELY THROUGH THESE INSTRUCTIONS BEFORE INSTALLING THE REDI-MAG.**

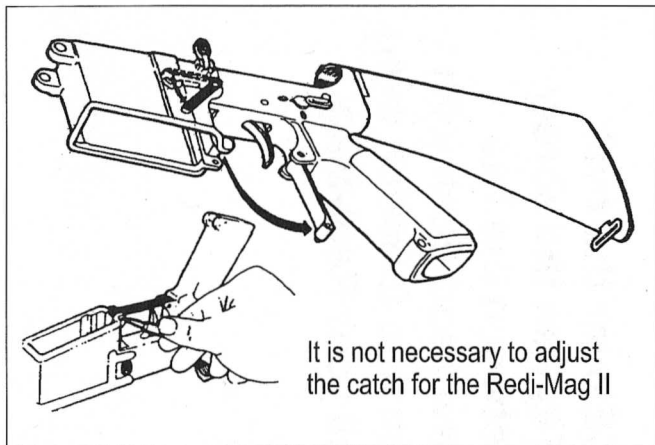

IF YOU HAVE THE MARK I MODEL – SEE THE OTHER SIDE OF THIS SHEET FIRST.

- 1) Open the trigger guard. Use a cartridge, pen or nail to depress the trigger guard release plunger (see small drawing above) and swing the trigger guard down to the winter position.

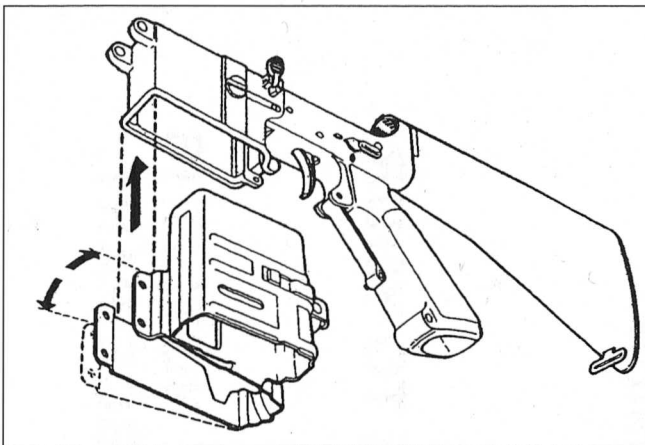

- 2) Slide the **REDI-MAG** clamp around the magazine housing of the rifle. Bend the right arm of the clamp slightly outward until it clears the raised lip around the bottom of the magazine housing. Be careful not to scratch the aluminum finish on the rifle, as the steel used in the **REDI-MAG** is very hard and tough. **NOTE:** While it is possible to install the **REDI-MAG** without disassembling the lower receiver assembly from the upper receiver assembly, it is easier to install if the receiver assemblies are separated.

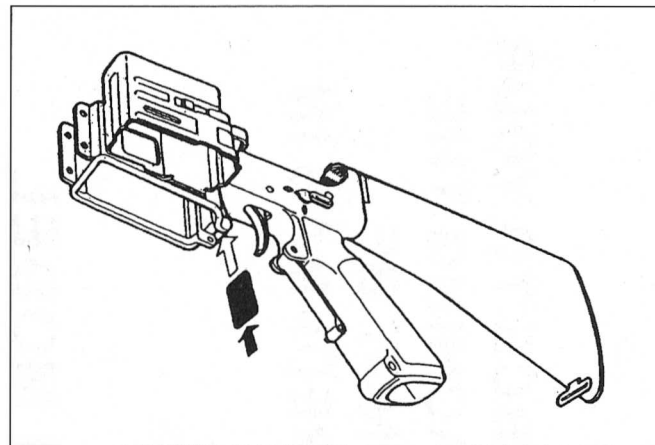

- 3) Slide the **Rear Gasket** (small rectangular) between the front arch of the trigger cut-out and the rearmost, curved portion of the **REDI-MAG** clamp.



**BOONIE PACKER PRODUCTS**

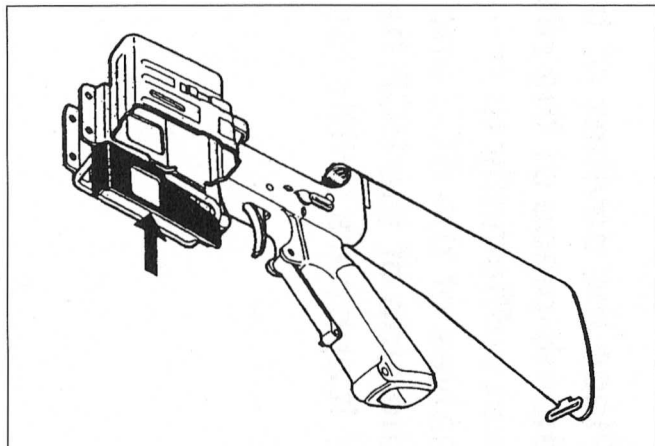

- 4) Position the **Left Gasket** (the one with the square hole) so:
  - a) the wide end is facing forward
  - b) the sloping edge is facing upward
- 5) Slide the gasket between the **REDI-MAG** and the rifle receiver. Carefully align the square hole in the gasket with the square hole in the **REDI-MAG**. This ensures that the magazine latch will operate without interference from the gasket, and that the rifle serial number is readily visible.

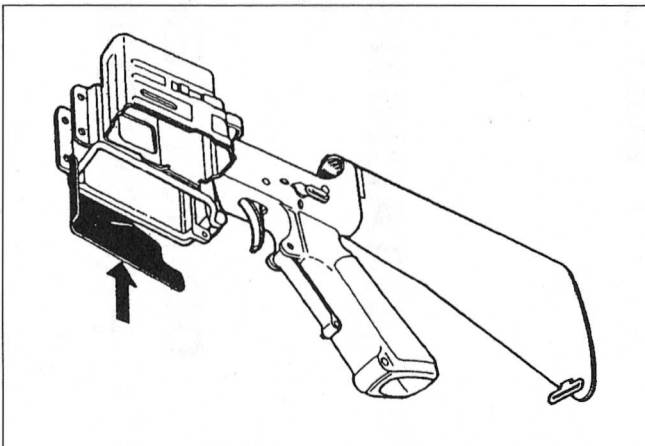

- 6) Position the **Right Gasket** so:
  - a) the wide end is facing forward
  - b) the sloping edge is facing upward
- 7) Slide the gasket between the **REDI-MAG** and the rifle receiver. Align the lower edge of the gasket with the lower edge of the **REDI-MAG** clamp.

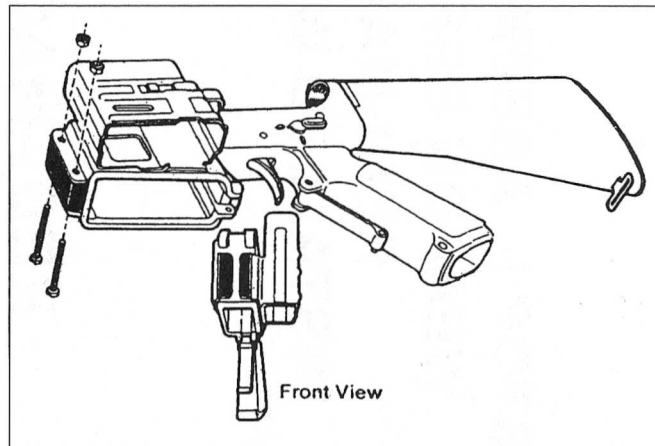

- 8) Fold the front edge of both gaskets flat against the front of the rifle magazine well: if installed properly there will be a gap of approximately 1/16" - 1/8" (1.6 - 3.2 mm) between the ends of the gaskets (see small drawing above).
- 9) Install the fore-end bumper block with the rounded edges facing forward. Install the machine screws and nylon-insert lock nuts as shown above.
- 10) Insert a magazine into the **REDI-MAG** until a positive "click" is heard. The spare magazine is now latched securely in place.